

HERMES
TOOLS

TECNA[®]

Resistance Welding Systems & Balancers

ATEX



COMPLIANT

ATmosphères EXplosibles

SPRING BALANCERS



Balancers Catalogue
ATEX Line

CAPACITY 0,4 ÷ 100 kg



www.tecna.net

CE
EAC
UK
CA
EN





TECNA S.P.A. - VIA MEUCCI, 27 - CASTEL SAN PIETRO TERME

TECNA produces and distributes a complete range of BALANCERS having a capacity from 0.2 kg to 180 kg and an available standard wire stroke up to 3 meters. The TECNA BALANCER is an essential device to eliminate the operator's labour, to increase productivity by cutting down tools handling time and to improve work quality. Furthermore, the use of the TECNA BALANCERS reduces hoses and cables wear and avoids eventual damages to both people and tools.

The application of the TECNA BALANCER is absolutely versatile: it may be used for bench or assembly line works and it may be suitably applied to small tools, industrial suspended welders and multiple screw drivers. The ergonomic structure of the TECNA balancers has been designed to facilitate each application of use, ranging from movement easiness to body robustness, from simple use to lifting power.

TECNA, as a primary manufacturer, realizes special as well as customized versions upon demand.



TECNA S.P.A. - VIA GRIMALDI



Made in Italy





TECNA, 25/27 - CASTEL SAN PIETRO TERME



ATEX  **COMPLIANT**
ATmosphères EXplosibles
SPRING BALANCERS

CE EAC UK CA

DIN 15112:1979

ATEX COMPLIANT

ATmosphères EXplosibles

WHY ATEX

TECNA was the first to develop a dedicated line with AtEx certification, suitable for use in areas with a potentially explosive atmosphere composed of flammable gases or combustible materials.

TECNA AX BALANCERS, depending on the models, are compatible with most flammable fumes, gases including Propane, Ethylene, Acetylene and Hydrogen (IIC group), as well as flammable dust.

Balancers are meant for safety and ergonomics and they must be able to follow you and your needs in every possible scenario. Therefore TECNA made balancers that can follow you also in dangerous situations, where even the tiniest spark can mean trouble.

AtEx certification, beside other features, requires products to be entirely conductive, grounded and with spark-proof materials. **TECNA AX BALANCERS** line guarantees this and more.

TECNA AX BALANCERS line is perfect for Oil&Gas applications, oil plants and refineries, chemical plants, but also tank washers, as well as situations with flour or flammable powders in suspension.



TECNA AX BALANCERS LINE was the first to obtain AtEx certification in 2009, to supply a solution for use in areas with a potentially explosive atmosphere or where grounding and conductivity are a requirement.

AtEx certification, beside other features, requires products to be entirely conductive, grounded and with spark-proof materials.

TECNA AX BALANCERS LINE guarantees this and more.

TECNA AX BALANCERS line is perfect for electronic assembly.

Overall resistance from ground point to carabiner is below 1 Ohm.



The challenge was to manufacture balancers with the same endurance and performance, which would be compliant with AtEx requirements, in a no-compromise line.

TECNA AX BALANCERS LINE performs equal to the classic **TECNA BALANCERS** line, simply with full compliance with AtEx strict requirement.

TECNA BALANCERS can follow you wherever you go, wherever you work. Just use them and you will see, the only limit is your creativity. And when you don't find an answer, just contact us and we'll listen.

ATEX RETRACTORS

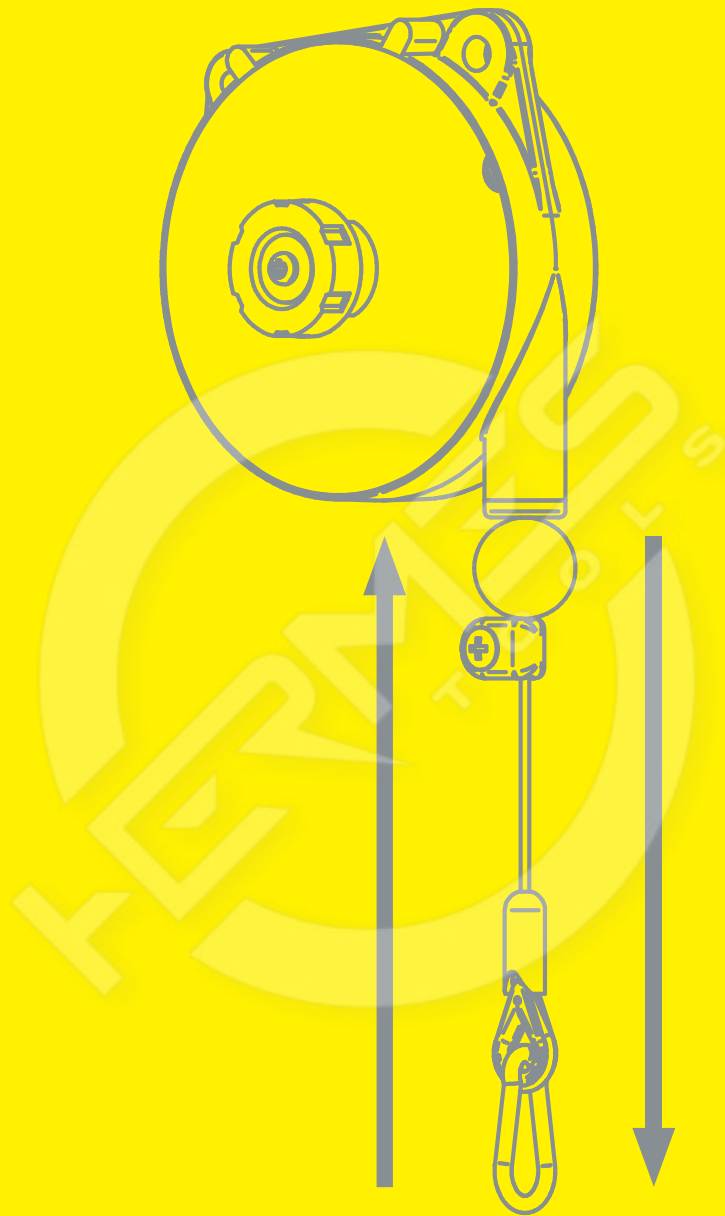

Use your instrument with minimum effort
When released, the load will return to its rest position



9310AX÷9313AX

9320AX÷9323AX

33



| | |
|--|-----------------|
| | Aluminium |
| | 1600 mm |
| | Stainless Steel |
| | 0,2÷3 kg |

ATEX **COMPLIANT**
 ATmosphères EXplosibles
 II 2G Ex h IIC T6 Gb

34



| | |
|--|-----------------|
| | Aluminium |
| | 2000 mm |
| | Stainless Steel |
| | 1÷8 kg |

ATEX **COMPLIANT**
 ATmosphères EXplosibles
 II 2G Ex h IIC T6 Gb
 II 2G Ex h IIB T6 Gb (9323AX)

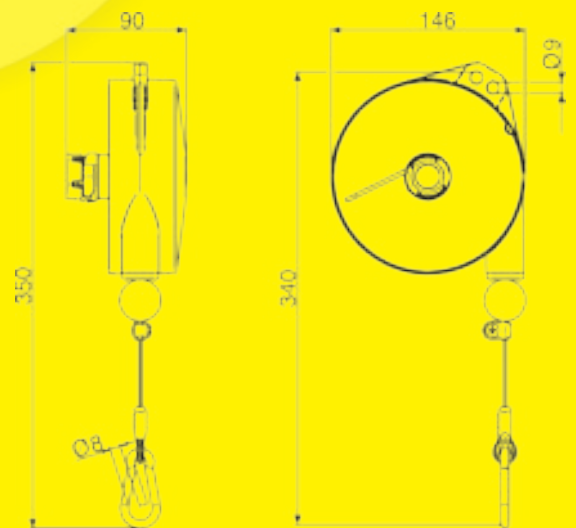
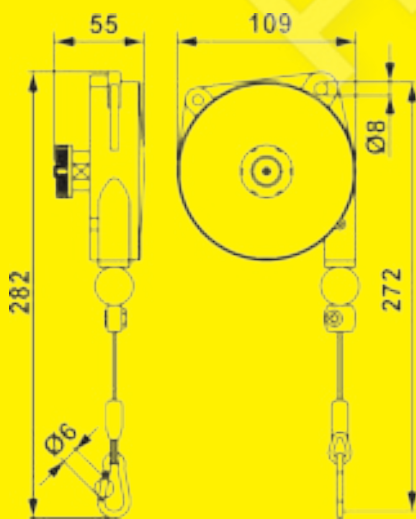

| Item | 9310AX | 9311AX | 9312AX | 9313AX |
|------|---------|--------|--------|--------|
| | 0,2÷0,5 | 0,4÷1 | 1÷2 | 2÷3 |
| | 0,55 | 0,57 | 0,60 | 0,74 |

| Item | 9320AX | 9321AX | 9322AX | 9323AX |
|------|--------|--------|--------|--------|
| | 1÷2,5 | 2÷4 | 4÷6 | 6÷8 |
| | 1,67 | 1,90 | 1,98 | 2,28 |

9336LAX÷9340AX

9346LAX÷9350AX

35



| | |
|--|-----------------|
| | Aluminium |
| | 2500 mm |
| | Stainless Steel |
| | 0,5÷14 kg |

ATEX COMPLIANT

ATmosphères EXplosibles

- II 2G Ex h IIC T6 Gb (9336LAX/9336AX)
- II 2G Ex h IIB T6 Gb (9337AX÷9339AX)
- II 2G Ex h IIA T6 Gb (9340AX)

36

STOP



| | |
|--|-----------------|
| | Aluminium |
| | 2500 mm |
| | Stainless Steel |
| | 0,5÷14 kg |

ATEX COMPLIANT

ATmosphères EXplosibles

- II 2G Ex h IIC T6 Gb (9346LAX/9346AX)
- II 2G Ex h IIB T6 Gb (9347AX÷9349AX)
- II 2G Ex h IIA T6 Gb (9350AX)

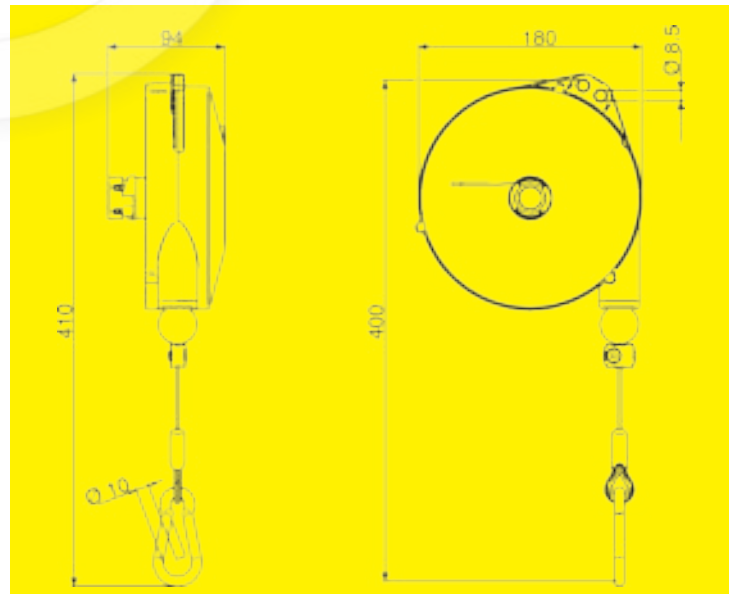
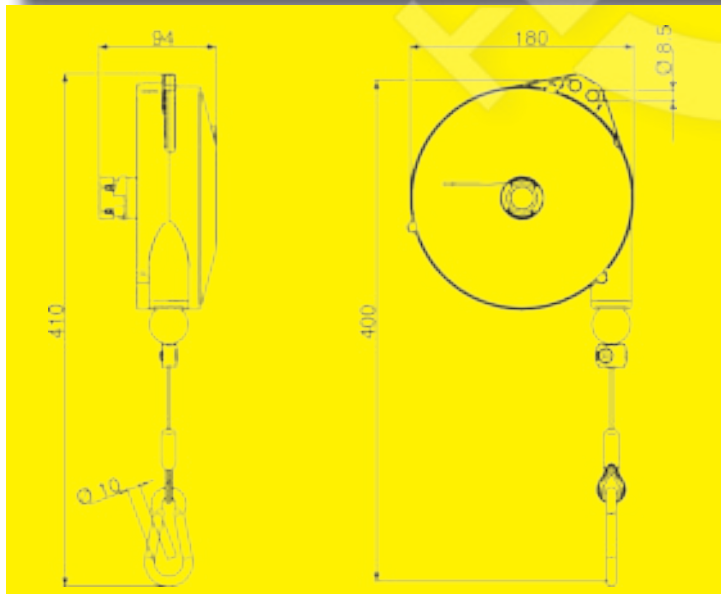

| Item | 9336LAX | 9336AX | 9337AX | 9338AX | 9339AX | 9340AX |
|------|---------|--------|--------|--------|--------|--------|
| | 0,5÷2 | 2÷4 | 4÷6 | 6÷8 | 8÷10 | 10÷14 |
| | 3,14 | 3,14 | 3,30 | 3,36 | 3,43 | 3,58 |

| Item | 9346LAX | 9346AX | 9347AX | 9348AX | 9349AX | 9350AX |
|------|---------|--------|--------|--------|--------|--------|
| | 0,5÷2 | 2÷4 | 4÷6 | 6÷8 | 8÷10 | 10÷14 |
| | 3,14 | 3,14 | 3,32 | 3,38 | 3,48 | 3,62 |

BALANCERS TECHNICAL FEATURES

ATEX  **COMPLIANT**
ATmosphères EXplosibles

| | 9310AX÷9313AX | 9320AX÷9323AX | 9336LAX÷9340AX | 9346LAX÷9350AX | |
|----|---------------|---------------|----------------|----------------|--|
| kg | 0.2÷3 | 1÷8 | 0,5÷14 | 0,5÷14 | Capacity |
| mm | 1600 | 2000 | 2500 | 2500 | Stroke |
| | ● | ● | ● | ● | Rugged construction, cast aluminium body |
| | ● | ● | ● | ● | Stainless steel rope |
| | ● | ● | ● | ● | Adjustable capacity |
| | ● | ● | ● | ● | Safety suspension |
| | | ● | ● | ● | Safety device against load dropping due to the spring breakage (capacity >3kg) |
| | ● | ● | ● | ● | Adjustable stroke limiting device |
| | ● | ● | ● | ● | Cable guide in antifriction material |
| | ● | ● | ● | ● | Inert spring drum assembly |
| | ● | ● | ● | ● | Polyamides thimble |

| ATEX CODING | 9310AX | 9311AX | 9312AX | 9313AX | 9320AX | 9321AX | 9322AX | 9323AX | 9336LAX | 9336AX | 9337AX | 9338AX | 9339AX | 9340AX | 9346LAX | 9346AX | 9347AX | 9348AX | 9349AX | 9350AX |
|----------------------|--------|--------|--------|--------|--------|--------|--------|--------|---------|--------|--------|--------|--------|--------|---------|--------|--------|--------|--------|--------|
| II 2G Ex h IIA T6 Gb | | | | | | | | | | | | | | ● | | | | | | ● |
| II 2G Ex h IIB T6 Gb | | | | | | | | ● | | | ● | ● | ● | | | | ● | ● | ● | |
| II 2G Ex h IIC T6 Gb | ● | ● | ● | ● | ● | ● | ● | ● | ● | ● | | | | | ● | ● | | | | |

PACKAGING FEATURES

ATEX  **COMPLIANT**
ATmosphères EXplosibles

| | 9310AX | 9311AX | 9312AX | 9313AX | 9320AX | 9321AX | 9322AX | 9323AX | 9336LAX | 9336AX | 9337AX |
|----|-------------|-------------|-------------|-------------|-------------|-------------|-------------|-------------|-------------|-------------|-------------|
| kg | 0,70 | 0,70 | 0,70 | 0,80 | 1,80 | 2,1 | 2,1 | 2,5 | 3,40 | 3,40 | 3,60 |
| mm | 204x112x62 | 204x112x62 | 204x112x62 | 204x112x62 | 254x149x96 | 254x149x96 | 254x149x96 | 254x149x96 | 304x186x100 | 304x186x100 | 304x186x100 |
| ● | 33 | 33 | 33 | 33 | 34 | 34 | 34 | 34 | 35 | 35 | 35 |
| | 9338AX | 9339AX | 9340AX | 9346LAX | 9346AX | 9347AX | 9348AX | 9349AX | 9350AX | | |
| kg | 3,70 | 3,70 | 3,80 | 3,40 | 3,40 | 3,60 | 3,70 | 3,80 | 3,90 | | |
| mm | 304x186x100 | 304x186x100 | 304x186x100 | 304x186x100 | 304x186x100 | 304x186x100 | 304x186x100 | 304x186x100 | 304x186x100 | | |
| ● | 35 | 35 | 35 | 36 | 36 | 36 | 36 | 36 | 36 | | |

ATEX ZERO GRAVITY BALANCERS

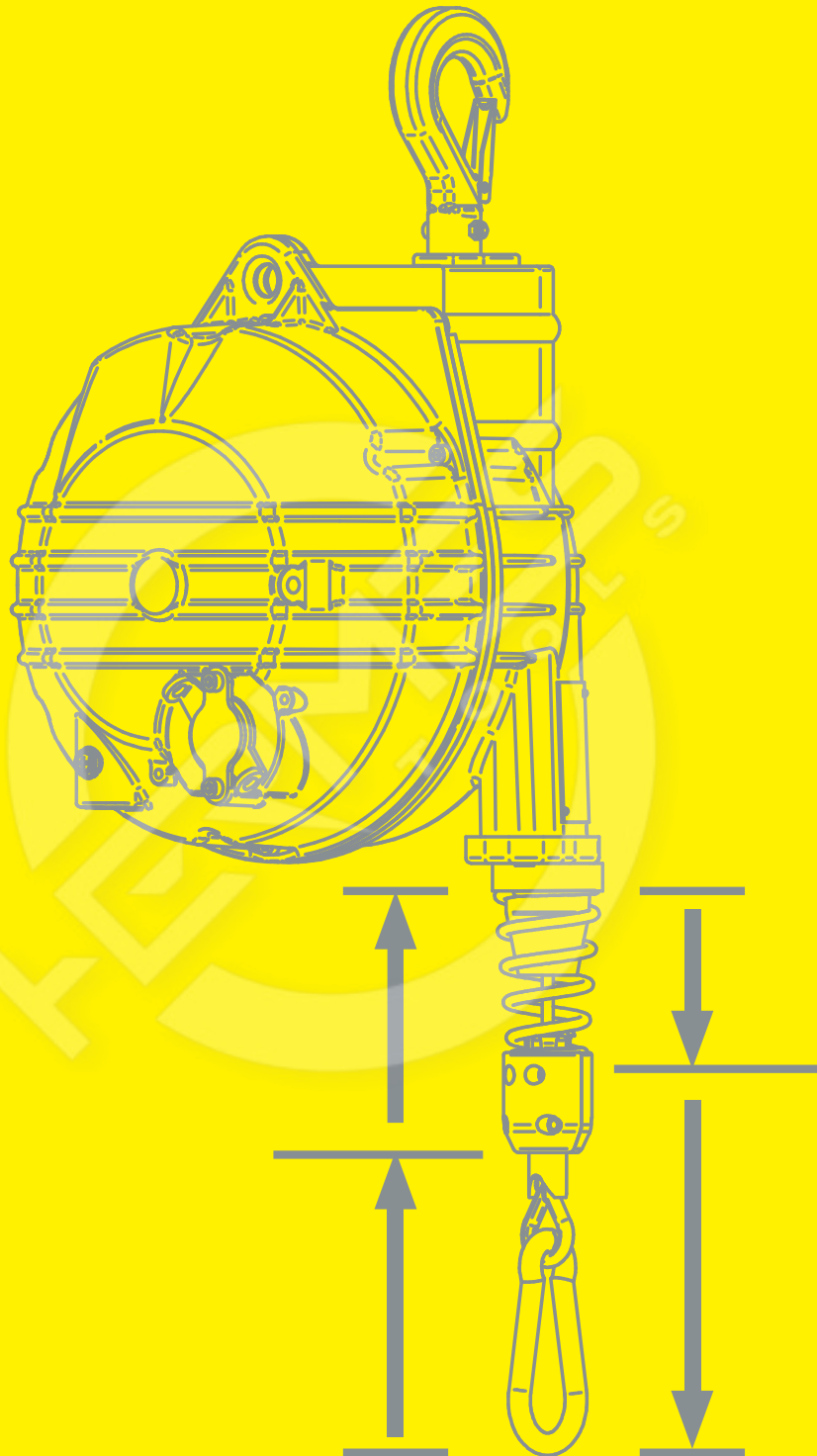

**Use your instrument without feeling its weight
The load maintains the position where you leave it**



37

| | |
|---|-----------------|
|  | Aluminium |
|  | 2000 mm |
| | Stainless Steel |
|  | 4÷25 kg |

Option F Brake device

The balancer is equipped with a friction/brake which controls the rotation speed of the drum. This option is feasible when placing a new order while it is not possible to assemble this device on balancers already installed.

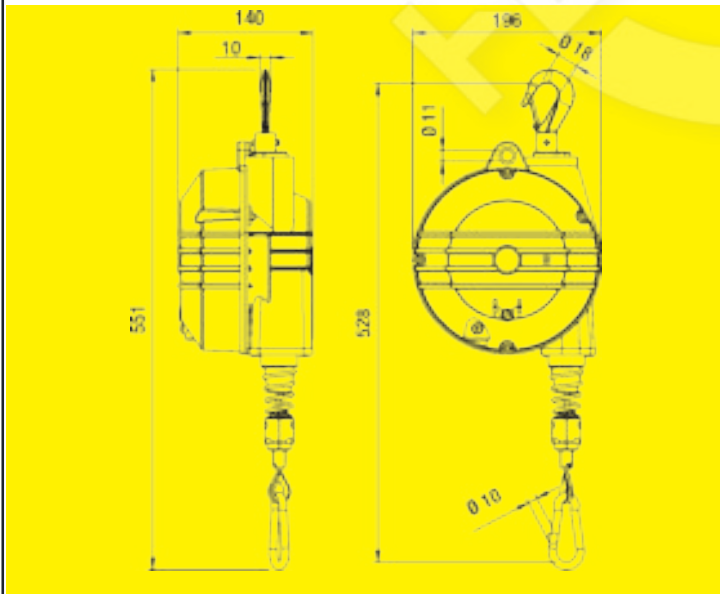

Option F



ATEX  **COMPLIANT**

ATmosphères EXplosibles

II 2G Ex h IIB T6 Gb (9354AX/9355AX)

II 2G Ex h IIA T6 Gb (9356AX÷9359AX)

II 2D Ex h IIIC T85°C Db

| Item | 9354AX | 9355AX | 9356AX | 9357AX | 9358AX | 9359AX |
|------|--------|--------|--------|--------|--------|--------|
|------|--------|--------|--------|--------|--------|--------|

| | | | | | | |
|--|-----|------|-------|-------|-------|-------|
|  | 4÷7 | 7÷10 | 10÷14 | 14÷18 | 18÷22 | 22÷25 |
|--|-----|------|-------|-------|-------|-------|

| | | | | | | |
|--|------|------|------|------|------|------|
|  | 4,94 | 5,30 | 5,67 | 6,26 | 5,89 | 6,53 |
|--|------|------|------|------|------|------|

38



Option RC (7270000004)
Conductive rotating hook group.



Control from the floor BC (7190000004)
Locking-unlocking device.

| | | |
|--|------------------------|-----------------|
| | Aluminium | |
| | 2100 mm | 9502AX ÷ 9509AX |
| | 2700 mm | 9520AX ÷ 9525AX |
| | Stainless Steel | |
| | 12 ÷ 100 kg | |

Option F



Option F Brake device

The balancer is equipped with a friction/brake which controls the rotation speed of the drum. This option is feasible when placing a new order while it is not possible to assemble this device on balancers already installed.

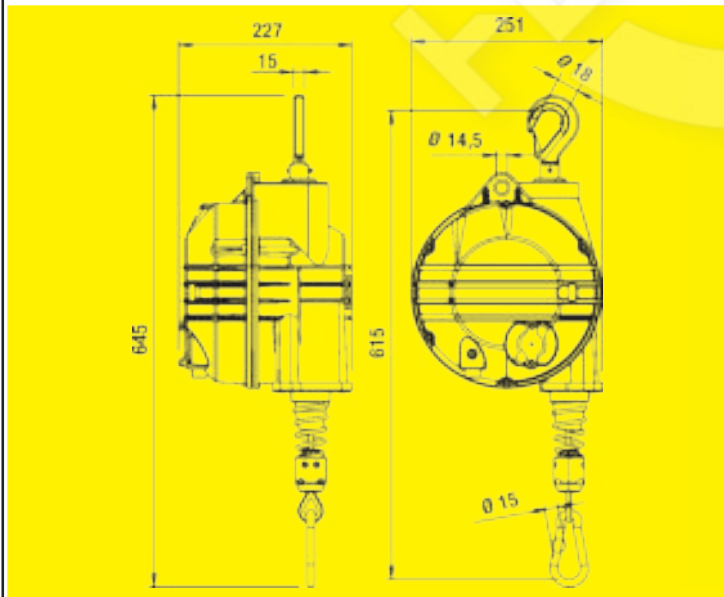

ATEX **COMPLIANT**

ATmosphères EXplosibles

II 2G Ex h IIA T6 Gb

II 2D Ex h IIIC T85°C Db

| Item | 9502AX | 9503AX | 9504AX | 9505AX | 9506AX | 9507AX | 9508AX | 9509AX | 9520AX | 9521AX | 9522AX | 9523AX | 9524AX | 9525AX |
|------|---------|---------|---------|---------|---------|---------|---------|----------|---------|---------|---------|---------|---------|---------|
| | 20 ÷ 30 | 30 ÷ 40 | 40 ÷ 50 | 50 ÷ 60 | 60 ÷ 70 | 70 ÷ 80 | 80 ÷ 90 | 90 ÷ 100 | 12 ÷ 20 | 20 ÷ 30 | 30 ÷ 40 | 40 ÷ 50 | 50 ÷ 60 | 60 ÷ 70 |
| | 12,60 | 15,20 | 15,50 | 16,70 | 15,50 | 17,70 | 16,20 | 16,80 | 12,80 | 12,60 | 15,80 | 15,40 | 16,60 | 15,70 |

BALANCERS TECHNICAL FEATURES

ATEX  **COMPLIANT**
ATmosphères EXplosibles

| | 9354AX÷9359AX | 9502AX÷9509AX | 9520AX÷9525AX | |
|----|---------------|---------------|---------------|--|
| kg | 4÷25 | 20÷100 | 12÷70 | Capacity |
| mm | 2000 | 2100 | 2700 | Stroke |
| ● | ● | ● | ● | Ribbed and sealed construction in aluminium alloy |
| ● | ● | ● | ● | Stainless steel rope |
| ● | ● | ● | ● | Adjustable capacity by means of a worm screw |
| ● | ● | ● | ● | Safety suspension |
| ● | ● | ● | ● | Safety device against load dropping due to the spring breakage (capacity >3kg) |
| ● | ● | ● | ● | Upper rotary suspension with safety hook |
| ● | ● | ● | ● | Locking device to block the load at any height |
| ● | ● | ● | ● | Adjustable stroke limiting device |
| ● | ● | ● | ● | Taper drum rotating on ball bearings |
| ● | ● | ● | ● | Cable guide in antifriction material |
| ● | ● | ● | ● | Rotary upper hook with ball bearing |
| ● | ● | ● | ● | Inert spring drum assembly |

ON REQUEST OPTIONS F & ACCESSORIES BC - RC

| | | | | |
|----|---|---|---|---------------------------------------|
| BC | | ● | ● | 7190000004: Locking-unlocking device. |
| RC | ● | ● | ● | RC: Rotary hook |
| F | ● | ● | ● | F: Brake device |

| ATEX CODING | 9354AX | 9355AX | 9356AX | 9357AX | 9358AX | 9359AX | 9502AX | 9503AX | 9504AX | 9505AX | 9506AX | 9507AX | 9508AX | 9509AX | 9520AX | 9521AX | 9522AX | 9523AX | 9524AX | 9525AX |
|--------------------------|--------|--------|--------|--------|--------|--------|--------|--------|--------|--------|--------|--------|--------|--------|--------|--------|--------|--------|--------|--------|
| II 2G Ex h IIA T6 Gb | | | ● | ● | ● | ● | ● | ● | ● | ● | ● | ● | ● | ● | ● | ● | ● | ● | ● | ● |
| II 2G Ex h IIB T6 Gb | ● | ● | | | | | | | | | | | | | | | | | | |
| II 2D Ex h IIIC T85°C Db | ● | ● | ● | ● | ● | ● | ● | ● | ● | ● | ● | ● | ● | ● | ● | ● | ● | ● | ● | ● |

PACKAGING FEATURES

ATEX  **COMPLIANT**
ATmosphères EXplosibles

| | 9354AX | 9355AX | 9356AX | 9357AX | 9358AX | 9359AX | 9502AX | 9503AX | 9504AX | 9505AX | 9506AX |
|------|--------------|--------------|--------------|--------------|--------------|--------------|--------------|--------------|--------------|--------------|--------------|
| kg | 6,00 | 6,40 | 6,80 | 7,40 | 7,00 | 7,60 | 14,40 | 17,00 | 17,30 | 18,50 | 17,30 |
| lb | 13,23 | 14,11 | 14,99 | 16,31 | 15,43 | 16,76 | 31,75 | 37,48 | 31,14 | 40,79 | 38,14 |
| mm | 525x206x175 | 525x206x175 | 525x206x175 | 525x206x175 | 525x206x175 | 525x206x175 | 590x265x260 | 590x265x260 | 590x265x260 | 590x265x260 | 590x265x260 |
| inch | 16,5x8,1x6,5 | 16,5x8,1x6,5 | 16,5x8,1x6,5 | 16,5x8,1x6,5 | 16,5x8,1x6,5 | 16,5x8,1x6,5 | 17,9x10,6x11 | 17,9x10,6x11 | 17,9x10,6x11 | 17,9x10,6x11 | 17,9x10,6x11 |
| ● | 37 | 37 | 37 | 37 | 37 | 37 | 38 | 38 | 38 | 38 | 38 |
| | 9507AX | 9508AX | 9509AX | 9520AX | 9521AX | 9522AX | 9523AX | 9524AX | 9525AX | | |
| kg | 19,50 | 18,00 | 18,60 | 14,60 | 14,40 | 17,60 | 17,20 | 18,40 | 17,50 | | |
| lb | 43,00 | 39,68 | 41,01 | 32,19 | 31,75 | 38,80 | 38,00 | 40,57 | 38,58 | | |
| mm | 590x265x260 | 590x265x260 | 590x265x260 | 590x265x260 | 590x265x260 | 590x265x260 | 590x265x260 | 590x265x260 | 590x265x260 | | |
| inch | 17,9x10,6x11 | 17,9x10,6x11 | 17,9x10,6x11 | 17,9x10,6x11 | 17,9x10,6x11 | 17,9x10,6x11 | 17,9x10,6x11 | 17,9x10,6x11 | 17,9x10,6x11 | | |
| ● | 38 | 38 | 38 | 38 | 38 | 38 | 38 | 38 | 38 | | |

TECNA S.p.A. Specifications subject to change without notice.

RETRACTORS & BALANCERS TABLES

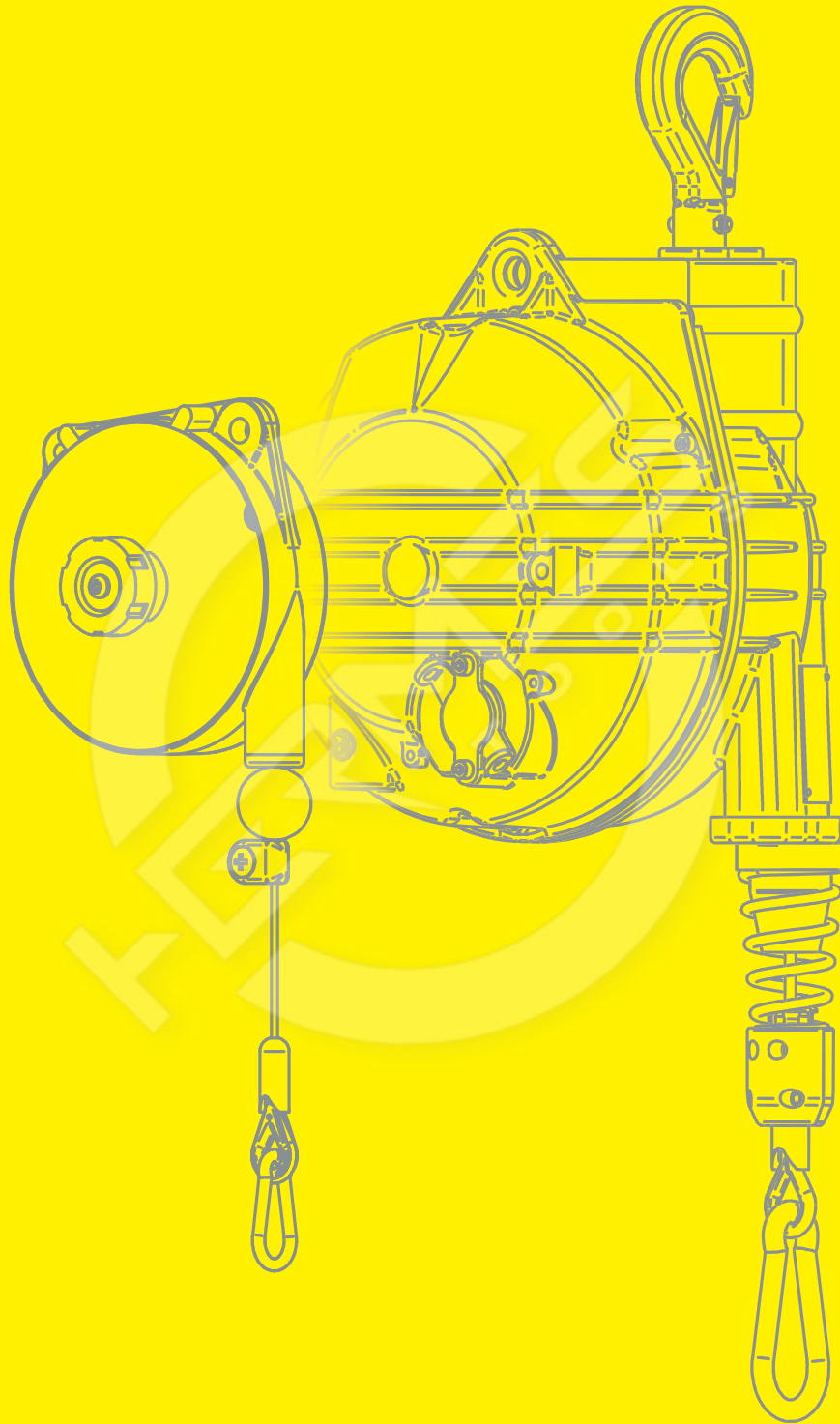

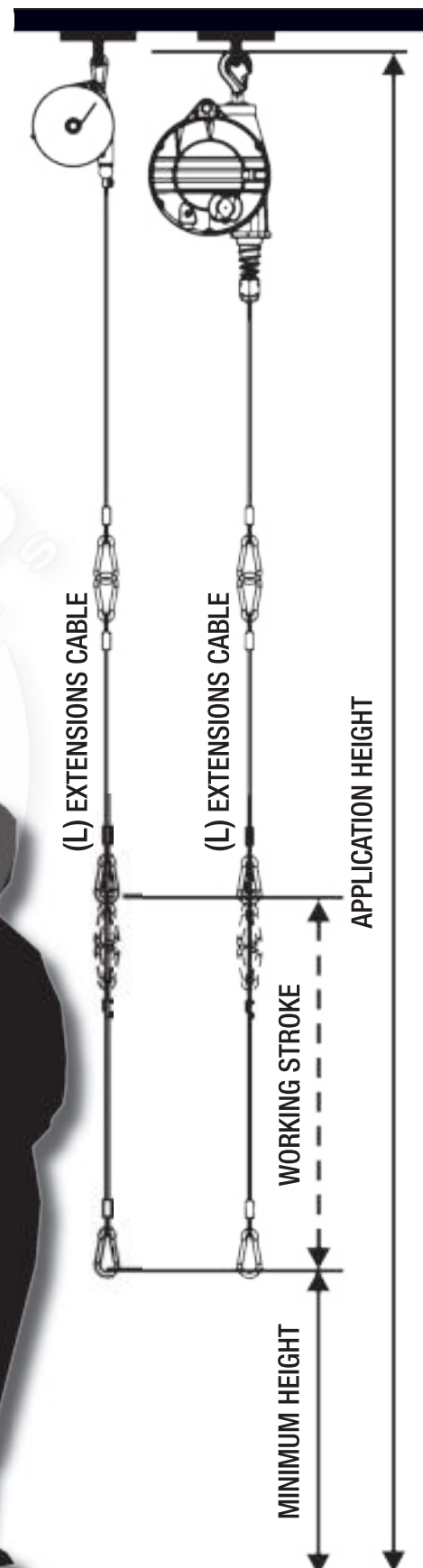

EXTANSION CABLE &
CONVERSION TABLES

| 9301÷03 / 9311÷13 (carabiner 40mm-1.57") EXTENSIONS CABLES Ø 2-0.08" | | | | |
|--|---------------|----------------------|-----------------|----------|
| (L) MM | CODE | STAINLESS STEEL ROPE | (A) - CARABINER | (L) inch |
| 500 | 7260000149 | 7260000144 | 21223 | 19.68 |
| 1000 | 7260000150 | 7260000145 | 21223 | 39.37 |
| 2500 | 7260000151 | 7260000146 | 21223 | 98.42 |
| 3000 | 7260000152 | 7260000147 | 21223 | 118.11 |
| 5000 | 7260000153 | 7260000148 | 21223 | 196.85 |
| 9320÷23 (carabiner 60mm-2.36") EXTENSIONS CABLES Ø 2-0.08" | | | | |
| (L) MM | CODE | STAINLESS STEEL ROPE | (A) - CARABINER | (L) inch |
| 500 | 7260000164 | 7260000144 | 20116 | 19.68 |
| 1000 | 7260000165 | 7260000145 | 20116 | 39.37 |
| 2500 | 7260000166 | 7260000146 | 20116 | 98.42 |
| 3000 | 7260000167 | 7260000147 | 20116 | 118.11 |
| 5000 | 7260000168 | 7260000148 | 20116 | 196.85 |
| 9336L÷50 (carabiner 80mm-3.14") EXTENSIONS CABLES Ø 2,5-0.10" | | | | |
| (L) MM | CODE | STAINLESS STEEL ROPE | (A) - CARABINER | (L) inch |
| 500 | 7260000159 | 7260000154 | 20115 | 19.68 |
| 1000 | 7260000160 | 7260000155 | 20115 | 39.37 |
| 2500 | 7260000161 | 7260000156 | 20115 | 98.42 |
| 3000 | 7260000162 | 7260000157 | 20115 | 118.11 |
| 5000 | 7260000163 | 7260000158 | 20115 | 196.85 |
| 9354÷59 (carabiner 80mm-3.14") EXTENSIONS CABLES Ø 3-0.12" | | | | |
| (L) MM | CODE | STAINLESS STEEL ROPE | (A) - CARABINER | (L) inch |
| 500 | 72967/0,5 | 45870/0,5 | 20115 | 19.68 |
| 1000 | 72967/1 | 45870/1 | 20115 | 39.37 |
| 2500 | 72967/2,5 | 45870/2,5 | 20115 | 98.42 |
| 3000 | 72967/3 | 45870/3 | 20115 | 118.11 |
| 5000 | 72967/5 | 45870/5 | 20115 | 196.85 |
| 9361÷71 / 9520÷25 (carabiner 100mm-3.94") EXTENSIONS CABLES Ø 4-0.16" | | | | |
| (L) MM | CODE | STAINLESS STEEL ROPE | (A) - CARABINER | (L) inch |
| 500 | 72968/0,5 | 45871/0,5 | 20132 | 19.68 |
| 1000 | 72968/1 | 45871/1 | 20132 | 39.37 |
| 2500 | 72968/2,5 | 45871/2,5 | 20132 | 98.42 |
| 3000 | 72968/3 | 45871/3 | 20132 | 118.11 |
| 5000 | 72968/5 | 45871/5 | 20132 | 196.85 |
| 9502÷09 (carabiner 100mm-3.94") EXTENSIONS CABLES Ø 5-0.20" | | | | |
| (L) MM | CODE | STAINLESS STEEL ROPE | (A) - CARABINER | (L) inch |
| 500 | 72969/0,5 | 45872/0,5 | 20132 | 19.68 |
| 1000 | 72969/1 | 45872/1 | 20132 | 39.37 |
| 2500 | 72969/2,5 | 45872/2,5 | 20132 | 98.42 |
| 3000 | 72969/3 | 45872/3 | 20132 | 118.11 |
| 5000 | 72969/5 | 45872/5 | 20132 | 196.85 |
| 94XX (carabiner 120mm-4.72") EXTENSIONS CABLES Ø 5-0.20" | | | | |
| (L) MM | CODE | STAINLESS STEEL ROPE | (A) - CARABINER | (L) inch |
| 500 | 72969/0,5/120 | 45872/0,5 | 20589 | 19.68 |
| 1000 | 72969/1/120 | 45872/1 | 20589 | 39.37 |
| 2500 | 72969/2,5/120 | 45872/2,5 | 20589 | 98.42 |
| 3000 | 72969/3/120 | 45872/3 | 20589 | 118.11 |
| 5000 | 72969/5/120 | 45872/5 | 20589 | 196.85 |



FOR ATEX BALANCERS

| ART. |  | |  | |  | |
|---------|---|---------------|---|-------|---|-------|
| | Kg | lb | mm | inch | Kg | lb |
| 9311AX | 0,4÷1 | 0,88÷2,20 | 1600 | 62,99 | 0,57 | 1,26 |
| 9312AX | 1÷2 | 2,20÷4,41 | 1600 | 62,99 | 0,60 | 1,32 |
| 9313AX | 2÷3 | 4,41÷6,61 | 1600 | 62,99 | 0,74 | 1,63 |
| 9320AX | 1÷2,5 | 2,20÷5,51 | 2000 | 78,74 | 1,67 | 3,68 |
| 9321AX | 2÷4 | 4,41÷8,82 | 2000 | 78,74 | 1,90 | 4,19 |
| 9322AX | 4÷6 | 8,82÷13,23 | 2000 | 78,74 | 1,98 | 4,37 |
| 9323AX | 6÷8 | 13,23÷17,63 | 2000 | 78,74 | 2,28 | 5,03 |
| 9336LAX | 0,5÷2 | 1,1÷4,41 | 2500 | 98,43 | 3,14 | 6,92 |
| 9336AX | 2÷4 | 4,41÷8,82 | 2500 | 98,43 | 3,14 | 6,92 |
| 9337AX | 4÷6 | 8,82÷13,23 | 2500 | 98,43 | 3,30 | 7,28 |
| 9338AX | 6÷8 | 13,23÷17,63 | 2500 | 98,43 | 3,36 | 7,41 |
| 9339AX | 8÷10 | 17,63÷22,05 | 2500 | 98,43 | 3,43 | 7,56 |
| 9340AX | 10÷14 | 22,05÷30,86 | 2500 | 98,43 | 3,58 | 7,89 |
| 9346LAX | 0,5÷2 | 1,1÷4,41 | 2500 | 98,43 | 3,14 | 6,92 |
| 9346AX | 2÷4 | 4,41÷8,82 | 2500 | 98,43 | 3,14 | 6,92 |
| 9347AX | 4÷6 | 8,82÷13,23 | 2500 | 98,43 | 3,32 | 7,32 |
| 9348AX | 6÷8 | 13,23÷17,63 | 2500 | 98,43 | 3,38 | 7,45 |
| 9349AX | 8÷10 | 17,63÷22,05 | 2500 | 98,43 | 3,48 | 7,67 |
| 9350AX | 10÷14 | 22,05÷30,86 | 2500 | 98,43 | 3,62 | 7,98 |
| 9354AX | 4÷7 | 8,82÷15,43 | 2000 | 78,74 | 4,94 | 10,89 |
| 9355AX | 7÷10 | 15,43÷22,05 | 2000 | 78,74 | 5,30 | 11,68 |
| 9356AX | 10÷14 | 22,05÷30,86 | 2000 | 78,74 | 5,67 | 12,5 |
| 9357AX | 14÷18 | 30,86÷39,68 | 2000 | 78,74 | 6,26 | 13,8 |
| 9358AX | 18÷22 | 39,68÷48,50 | 2000 | 78,74 | 5,89 | 12,99 |
| 9359AX | 22÷25 | 48,50÷55,12 | 2000 | 78,74 | 6,53 | 14,4 |
| 9502AX | 20÷30 | 44,10÷66,14 | 2100 | 82,68 | 12,60 | 27,78 |
| 9503AX | 30÷40 | 66,14÷88,18 | 2100 | 82,68 | 15,20 | 33,51 |
| 9504AX | 40÷50 | 88,18÷110,23 | 2100 | 82,68 | 15,50 | 34,17 |
| 9505AX | 50÷60 | 110,23÷132,28 | 2100 | 82,68 | 16,70 | 36,82 |
| 9506AX | 60÷70 | 132,28÷132,28 | 2100 | 82,68 | 15,50 | 34,17 |
| 9507AX | 70÷80 | 132,28÷176,37 | 2100 | 82,68 | 17,70 | 39,02 |
| 9508AX | 80÷90 | 176,37÷198,42 | 2100 | 82,68 | 16,20 | 35,71 |
| 9509AX | 80÷100 | 176,37÷220,46 | 2100 | 82,68 | 16,80 | 37,04 |
| 9520AX | 12÷20 | 26,46÷44,10 | 2700 | 106,3 | 12,80 | 28,22 |
| 9521AX | 20÷30 | 44,10÷66,14 | 2700 | 106,3 | 12,60 | 27,78 |
| 9522AX | 30÷40 | 66,14÷88,18 | 2700 | 106,3 | 15,80 | 34,83 |
| 9523AX | 40÷50 | 88,18÷110,23 | 2700 | 106,3 | 15,40 | 33,95 |
| 9524AX | 50÷60 | 110,23÷132,28 | 2700 | 106,3 | 16,60 | 36,6 |
| 9525AX | 60÷70 | 132,28÷132,28 | 2700 | 106,3 | 15,70 | 34,61 |



TECNA 

Advanced Resistance Welding Systems and Balancers

GPS N44° 24' 24" - E11° 35' 13"

ATEX  **COMPLIANT**

ATmosphères EXplosibles

Via Meucci, 27
40024 - Castel San Pietro Terme (BO)
Italy

Tel. +39 051 695 4411
Fax +39 051 654 4490

www.tecna.net
vendite@tecna.net
sales@tecna.net